



Model P-900 Viscosity Analyzer



On-line Viscosity Analyzer for continuous measurement of absolute or dynamic viscosity of Newtonian fluids.

- ▶ Customizable 2-4000 cP Sample Range (optional kinematic output in cSt)
- ▶ Continuous Sample Viscosity output
- ▶ Does not require atmospheric recovery system
- ▶ Superior repeatability exceeding ASTM D-445
- ▶ Increased reliability with operating uptime better than 99%

The Model P-900 Viscosity Analyzer is combining the latest, state-of-the-art technology with over 20 years of industry experience. The result is an unsurpassed, high-quality Viscosity measurement system that produces the process control signal required to perform today's optimized and cost-efficient petroleum product quality control operations.

The updated design combines the traditional, reliable oil bath viscosity with key systems control upgrades. With the end user in mind, attention to design detail allows for ease of maintenance previously thought unattainable by conventional systems.

APPLICATION

In today's highly competitive environment, oil refiners are demanding instrumentation that aids in the optimization of the refining process. Therefore, refineries require a reliable and accurate viscosity analysis system to meet the required specifications. This analysis will allow the operators to optimize the refining process and therefore lower production costs while improving product quality.

Typical application locations are where automatic on-line composition analysis for verifying product quality and performance specifications is required like lube oil manufacturing and blending, fuel oil blending or controlling the dilution of residual fuels, heavy fuels and bitumen to constant viscosity specifications.

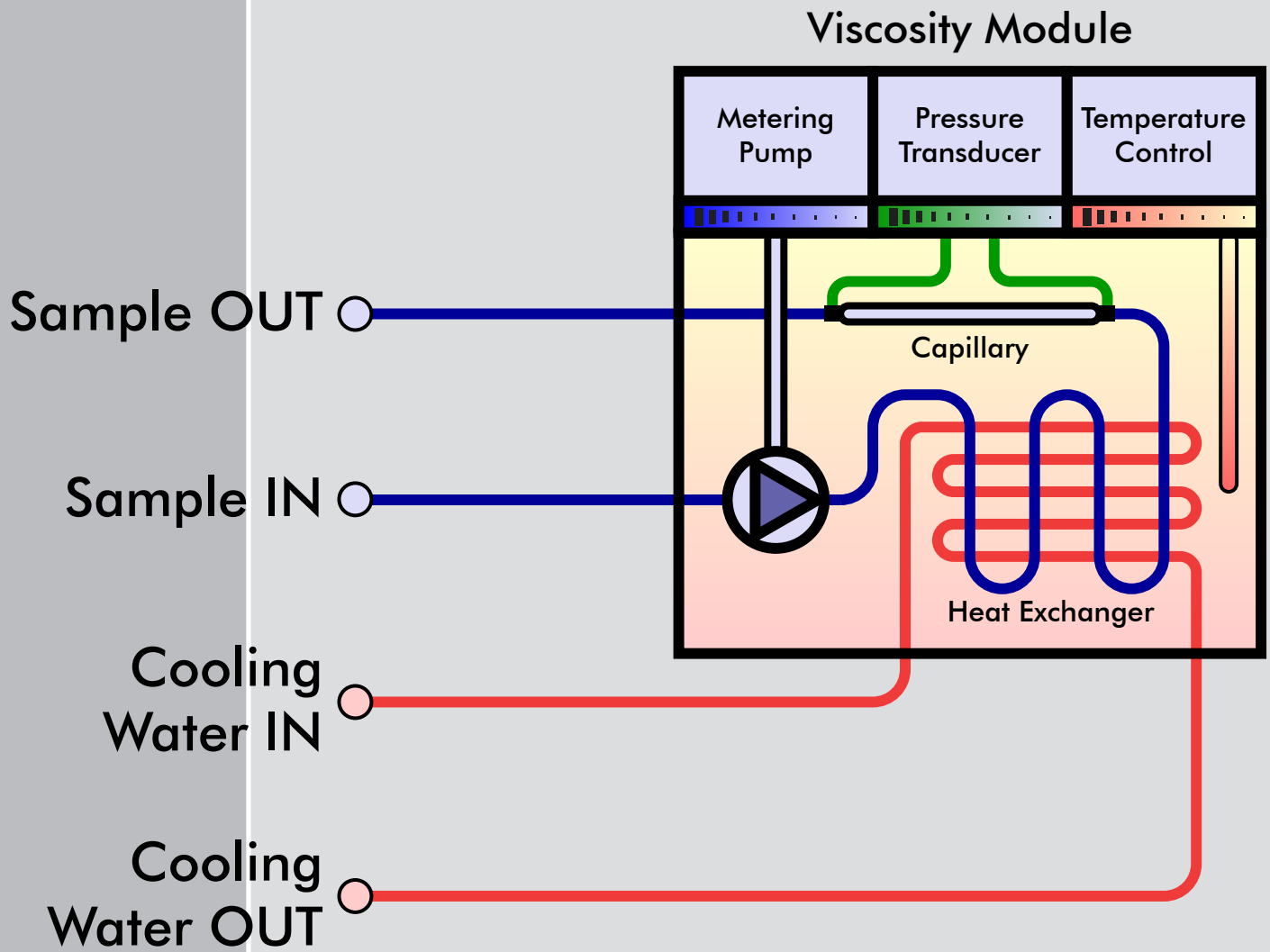

OPERATING PRINCIPLE

The P-900 measurement cycle is designed to correlate to the ASTM Method D-445.

The analysis is based on the Hagan-Poiseuille principle, which states that a fluid's pressure differential across a capillary will vary proportionally to the fluid's absolute viscosity.

Sample is continuously refreshed via a bypass line on the instrument. A filtered slipstream sample is pulled from this line into a heat exchanger located in a precisely temperature controlled oil bath, which brings the sample temperature to the specified analysis temperature. An AC synchronous motor and dual precision pumping system controls at a constant rate a small portion of this sample through a capillary restriction, where the differential pressure is measured across the capillary. The sample returns to the process line after leaving the capillary tube. The differential pressure measurements are processed by the instrument and a corresponding absolute or dynamic viscosity (cP) is reported.

The analyzer inherently measures absolute or dynamic viscosity (cP) and must correct for sample density to calculate kinematic viscosity. An optional input for a separate density measurement is available for highest accuracy conversion to kinematic units (cSt).

While continuously streaming viscosity data, the P-900 also monitors several system parameters in order to assure a reliable measurement. Bath temperature, and bath oil level are all continuously monitored to assure system reliability. An optional sample conditioning system can be added to handle samples of extreme temperatures and/or heavy particulates.

DIMENSIONS inch (mm)

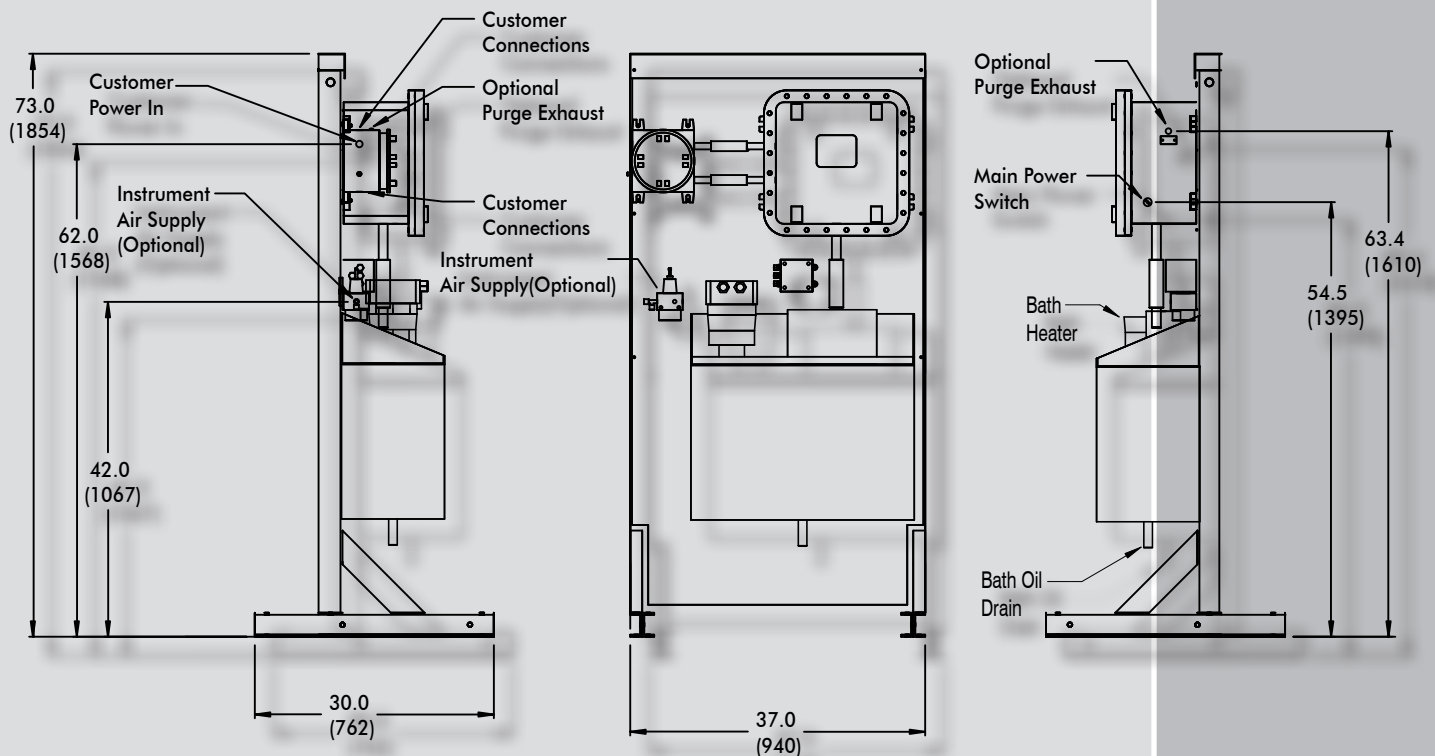

SPECIFICATIONS

ANALYSIS PERFORMANCE	
Measurement Cycle Time	Continuous, T90 Viscosity 180 sec
Measurement Range	2-4000 cP, Customizable based on Capillary Specification
Repeatability	± 1% Full Scale
Reproducibility	Meets or exceeds ASTM Method D-445
Accuracy	Meets or exceeds ASTM Method D-445
Temperature Accuracy	± 0.2°F (± 0.1°C)
SAMPLE REQUIREMENTS	
Sample Bypass Flow Rate	Min. 2 gal/hr (0.125 L/min)
Sample Return Pressure	Atmospheric – Max. 150 psi (10 bar) optional high pressure sample recovery system available
Sample Pressure	Min. 20 psi (1.4 bar) – Max. 375 psi (25 bar) optional sample conditioning system available
Sample Temperature	± 50°F (28°C) of bath temperature set point
Sample Particulates	less than 10 µm - optional sample conditioning system available
Sample Conditions	homogenous, single-phase sample without water or water moisture
ENCLOSURE/INSTALLATION REQUIREMENTS	
Dimensions	Width 37.0 in (940mm) – Height 73.0 in (1854mm) – Depth 30.0 in (762mm)
Weight	approximately 350 lbs (159 kg)
Operating Temperature	Min. 40°F (5°C) – Max. 105°F (40°C)
Enclosure Material/Rating	NEMA 4X / IP65 / ATEX rated EExd Enclosures
Area Classification	NEC Class 1 Div 1 Group D or ATEX Zone1 II B + H2 T4
Power	100 to 125VAC or 200 to 240 VAC, 50/60 Hz, single phase, 20A
Cabinet Purge Gas Supply	Instrument grade air at Min. 40 psi (2.7 bar) – Max. 100 psi (6.8 bar)
Coolant/Steam Supply	0.5 gal/min (2 l/min) maximum at 10°F (6°C) below bath set point
Enclosure Spill Drain Pressure	Atmospheric
END USER CONNECTIONS	
Analog Output Signal	single isolated 4-20 mA output (optional second output available), selectable for sample Viscosity and Viscosity Index values, analyzer system/maintenance warning or analysis measurement indication
Relay Output Contact	three SPDT Relays with contacts rated at 3A resistive load at 250VAC, selectable for sample RVP value alarm, analyzer maintenance warning or analyzer fault alarm
Serial Input/Output Signal	single RS232 or RS485 bi-directional / optional ModBus output available

HOW TO ORDER

ANALYZER SYSTEMS	
Catalog Number P-900-1400	ORB Instruments Model P-900 Viscosity Analyzer, Ex Housing NEC/CSA
Catalog Number P-900-1500	ORB Instruments Model P-900 Viscosity Analyzer, Ex Housing ATEX/CSA
OPTIONS	
Catalog Number 700538	Standard Panel Mount Sample Conditioning System
ACCESSORIES	
Catalog Number 700478	1-Year Spare Parts Kit for P-900/P-950 Viscosity/Viscosity Index Analyzer
Catalog Number 700479	2-Year Spare Parts Kit for P-900/P-950 Viscosity/Viscosity Index Analyzer

